

# RKDEW FRESH WATER COOLED CONDENSER

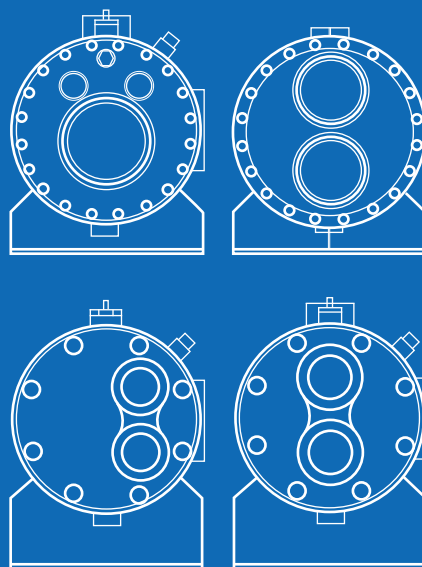



# ABOUT US

Refkar is one of the preferred institutions in the Turkish market for heat transfer products related to freon systems. With its 15 years of experience, it aims to gain strength and become a global brand in the international market.



## OUR FACTORY

It performs production in international standards with its 3.500 m<sup>2</sup> closed factory area established on 6.500 m<sup>2</sup> outdoor area, advanced technology production systems, and trained operator staff.



## COMPETENT STAFF

Since its establishment, Refkar has worked with a highly skilled team. It has trained and developed its employees within the framework of their competencies.



## FAIRS AND TRAVELS

Refkar has conducted business trips, partner visits, and participated in fairs to more than 50 countries. As a result, it has succeeded in becoming a recognized brand in the international market.



## PERFORMANCE

Refkar Shell&Tube Condensers are used in industrial and comfort cooling units. Refkar RKDEW and RKMDEW series Shell&Tube Condensers are manufactured in order to provide low pressure loss and high efficiency starting from a cooling capacity of 20 kW up to a capacity of 1680 kW under standard working conditions. RKDEW series Shell&Tube condensers are used in cooling applications where city water and storage water are used while RKMDEW series Shell&Tube condensers are used in cooling applications with sea water. Having adopted customer satisfaction as its main principle, Refkar also renders services for customer focused projects under different working conditions in addition to its standard product range.

## DESIGN AND MATERIAL

Refkar Shell&Tube Condensers are designed in order to minimize performance decreasing factors such as vibration and corrosion. RKMDEW series Shell&Tube condensers are designed and manufactured as resistant to corrosive effects of sea water. Materials used in Refkar Shell&Tube Condensers are selected according to "European Pressure Vessel Codes". Materials used in Refkar shell&tube type evaporators are chosen in compliance with "European Pressure Vessel Codes"

### RKDEW Shell&Tube Condensers;

- Heat transfer pipes with a special geometry and inside and outside grooves enabling the heat transfer are made of copper
- Tube sheets and bodies are made of steel
- Head Covers are made of cast iron
- Bolts are made of steel alloy
- Gaskets are made of asbestos free materials that are compatible with HCFC and HCF cooling gases.



## QUALITY AND TEST

Mechanical calculations of Refkar Shell&Tube Condensers are made in accordance with TS EN13445-3 standard and with a CE certificate in compliance with ISO 9001:2008 Quality Management System. Refkar Shell&Tube Condensers are assessed through a nitrogen test with a gas side of 30 bars and a water side of 12 bars. Refkar issues a guarantee of 2 years for all of its products against manufacturing defects.

Approval	PS		Ts min	Ts max	Category
	Tube Side	Shell Side			
CE/EAC	10 bar	30 bar	-10 °C	90 °C	Up to Cat.IV, 2014/68/EU

## FOULING FACTOR

Fouling factor (f.f.) is important in selecting an condenser. The fouling factor levels under certain conditions are given below.

Closed-circuit mains water	f.f.= 0,000043 m <sup>2</sup> K/W
Open-circuit mains water	f.f.= 0,000086 m <sup>2</sup> K/W
Glycol solution < %40	f.f.= 0,000086 m <sup>2</sup> K/W
Glycol solution > %40	f.f.= 0,000172 m <sup>2</sup> K/W

## ANTIFREEZE RECOMMENDATIONS

The table below lists the recommended glycol solution for low-temperature operating conditions.

Freezing Point [°C]	Ethilene Glycol [% Weight]	Propylene Glycol [% Weight]
-5	12	16
-10	22	26
-15	30	34
-20	36	40
-25	40	44
-30	44	48
-35	48	52
-40	52	56

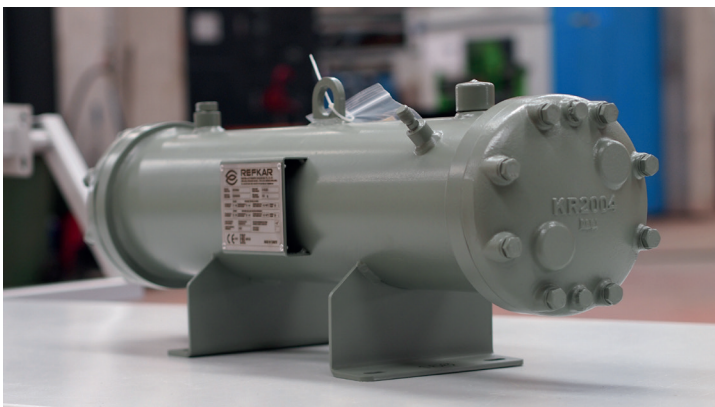

The values listed in the table were calculated based on the following operating conditions.

Refrigerant	Inlet water temperature	Outlet water temperature	Condensation temperature	Pollution factor	Superheat value
R407C	28°C	33°C	42°C	0,000043 m <sup>2</sup> K/W	3 K

MODEL	Q Nominal (kW)	ΔP Nominal (kPa)	W Nominal (m <sup>3</sup> /h)	W Max (m <sup>3</sup> /h)	Pass	Gas Volume (L)	Water Volume (L)
20	22	16	3,5	4,1	4	6,3	3,5
35	33	29	6,1	7,0	4	5,6	4,1
45	42	30	7,8	8,9	4	9	4,8
55	51	33	9,5	10,8	4	8,2	5,5
65	58	31	11,2	12,5	4	7,5	6,2
65C	65	57	10,4	12,1	4	13,2	6,3
75C	79	65	12,9	14,7	4	12,1	7,3
90C	94	73	15,6	17,2	4	11	8,2
60	60	19	11	12,7	2	20,3	7,0
90	81	22	15,6	17,9	2	18,8	8,4
100	94	21	17,3	19,7	2	17,2	9,8
120	111	25	20,8	23,7	2	15,7	11,1
130	120	27	22,4	25,4	2	14,9	11,8
145	141	46	25,1	28,9	2	22,4	12,1
165	163	50	28,6	29,9	2	20,4	13,9
180	176	36	31,2	36,0	2	19,4	14,7
200	205	33	34,6	40,5	2	27	18,1
220	227	33	38,1	44,6	2	25	19,8
245	251	48	42,4	49,7	2	36,5	21,6
265	273	52	45,9	53,6	2	34,5	23,4

Q Nominal (kw)	Nominal cooling capacity
ΔP Nominal (kPa)	Nominal water circuit pressure loss
W Nominal (m <sup>3</sup> /h)	Nominal water flow
W Max (m <sup>3</sup> /h)	Maximum water flow
Pass	Number of water crossings
Gas Volume (L)	Coolant circuit volume
Water Volume (L)	Water circuit volume

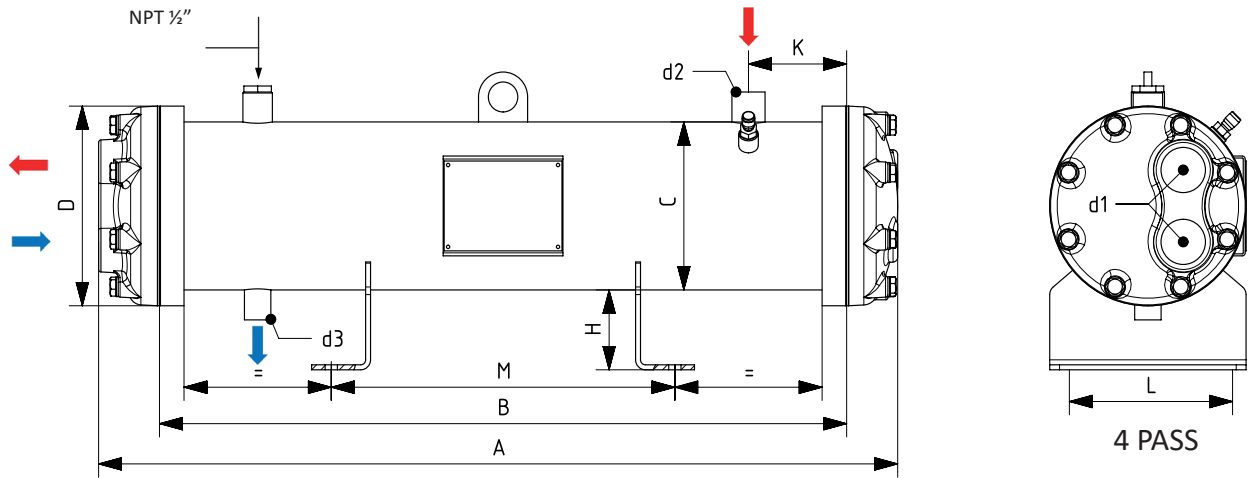

MODEL	A(mm)	B(mm)	C (mm)	D(mm)	H(mm)	K(mm)	L(mm)	M(mm)	d1	d2	d3	P (kg)
20	790	700	140	170	80	100	120	350	G 1"	W 22	W 16	32
35	790	700	140	170	80	100	120	350	G 1"	W 22	W 16	34
45	815	700	168	200	80	100	150	350	G 1 1/2"	W 28	W 22	45
55	815	700	168	200	80	100	150	350	G 1 1/2"	W 28	W 22	46
65	815	700	168	200	80	100	150	350	G 1 1/2"	W 28	W 22	47
65C	1115	1000	168	200	80	100	150	500	G 1 1/2"	W 28	W 22	55
75C	1115	1000	168	200	80	100	150	500	G 1 1/2"	W 28	W 22	57
90C	1115	1000	168	200	80	100	150	500	G 1 1/2"	W 28	W 22	59
60	1515	1400	168	200	80	100	150	700	G 2"	W 35	W 28	65
90	1515	1400	168	200	80	100	150	700	G 2"	W 35	W 28	68
100	1515	1400	168	200	80	150	150	700	G 2"	W 35	W 28	71
120	1515	1400	168	200	80	150	150	700	G 2"	W 35	W 28	73
130	1515	1400	168	200	80	150	150	700	G 2"	W 35	W 28	75
145	1915	1800	168	200	80	150	150	900	G 2"	W 42	W 35	85
165	1915	1800	168	200	80	150	150	900	G 2"	W 42	W 35	89
180	1915	1800	168	200	80	150	150	900	G 2"	W 42	W 35	91
200	1915	1800	194	250	80	150	180	900	G 2 1/2"	W 42	W 35	124
220	1915	1800	194	250	80	150	180	900	G 2 1/2"	W 42	W 35	128
245	1915	1800	219	250	80	150	200	900	G 2 1/2"	W 54	W 42	139
265	1915	1800	219	250	80	150	200	900	G 2 1/2"	W 54	W 42	143

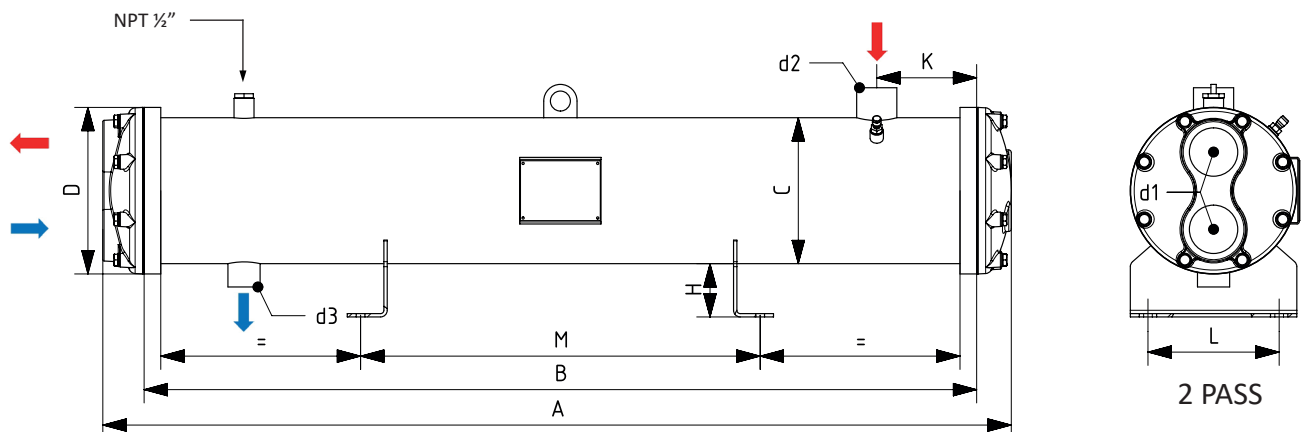

The values listed in the table were calculated based on the following operating conditions.

Refrigerant	Inlet water temperature	Outlet water temperature	Condensation temperature	Pollution factor	Superheat value
R407C	28°C	33°C	42°C	0,000043 m <sup>2</sup> K/W	3 K

MODEL	Q Nominal (kW)	ΔP Nominal (kPa)	W Nominal (m <sup>3</sup> /h)	W Max (m <sup>3</sup> /h)	Pass	Gas Volume (L)	Water Volume (L)
285	295	55	49,3	57,2	2	32,5	25,1
315	321	42	54,2	64,0	2	64,9	28,1
340	345	59	58,8	69,1	2	63	29,8
360	380	44	62,3	72,9	2	59	33,3
400	424	48	69,2	80,4	2	55	36,8
450	472	55	77,9	90,1	2	51,1	40,4
480	498	37	83,2	98,2	2	89	44,6
520	557	37	90	105,8	2	83	49,9
550	596	38	95,2	111,9	2	79	53,4
610	649	43	106	124,0	2	75,1	57,0
675	702	49	117	136,3	2	71,1	60,5
760	793	37	132	155,8	2	92,1	81,4
840	867	41	145	170,9	2	85,2	87,5
940	1039	49	163	191,1	2	144	109,6
1040	1178	51	180	210,6	2	131,9	120,4
1100	1243	54	190	222,9	2	125,3	126,3
1220	1350	45	211	246,9	2	180,1	140,8
1360	1489	50	235	274,5	2	169,1	150,6
1520	1670	39	263	305,1	2	222,3	174,3
1680	1849	41	291	337,6	2	205,8	188,9

Q Nominal (kW)	Nominal cooling capacity
ΔP Nominal (kPa)	Nominal water circuit pressure loss
W Nominal (m <sup>3</sup> /h)	Nominal water flow
W Max (m <sup>3</sup> /h)	Maximum water flow
Pass	Number of water crossings
Gas Volume (L)	Coolant circuit volume
Water Volume (L)	Water circuit volume



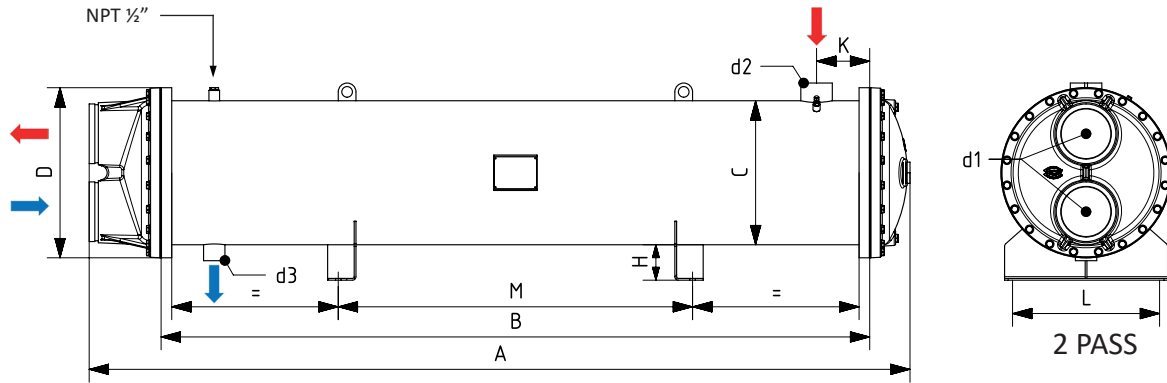

MODEL	A(mm)	B(mm)	C (mm)	D(mm)	H(mm)	K(mm)	L(mm)	M(mm)	d1	d2	d3	P (kg)
285	1915	1800	219	250	80	150	180	900	G 2 ½"	W 54	W 42	147
315	1925	1800	273	295	100	150	240	900	G 3"	W 54	W 42	181
340	1925	1800	273	295	100	150	240	900	G 3"	W 54	W 42	185
360	1925	1800	273	295	100	150	240	900	G 3"	W 54	W 42	193
400	1925	1800	273	295	100	150	240	900	G 3"	W 54	W 42	201
450	1925	1800	273	295	100	150	240	900	G 3"	W 54	W 42	208
480	1940	1800	324	350	100	150	280	900	G 4"	W 54	W 42	248
520	1940	1800	324	350	100	150	280	900	G 4"	W 54	W 42	259
550	1940	1800	324	350	100	150	280	900	G 4"	W 54	W 42	267
610	1940	1800	324	350	100	150	280	900	G 4"	W 80	W 54	274
675	1940	1800	324	350	100	150	280	900	G 4"	W 80	W 54	283
760	2175	1800	356	430	100	150	320	900	J 5"	W 80	W 54	352
840	2175	1800	356	430	100	150	320	900	J 5"	W 80	W 54	366
940	2415	2000	406	480	100	150	370	1000	J 6"	W 80	W 54	466
1040	2415	2000	406	480	100	150	370	1000	J 6"	W 80	W 54	490
1100	2415	2000	406	480	100	150	370	1000	J 6"	W 80	W 54	503
1220	2435	2000	457	530	100	150	420	1000	J 6"	W 100	W 80	592
1360	2435	2000	457	530	100	150	420	1000	J 6"	W 100	W 80	614
1520	2455	2000	508	580	100	150	470	1000	J 6"	W 100	W 80	725
1680	2455	2000	508	580	100	150	470	1000	J 6"	W 100	W 80	758

ACCESSORIES

Welded Connection (W)

Dimensions				
CODE	A	B	ID	OD
W 16	15	30	16,2	21,3
W 19	15	30	19,4	25
W 22	15	30	22,6	26,9
W 28	15	30	28,8	33,7
W 35	15	30	35,4	42,4
W 42	15	35	42,3	48,3
W 54	15	45	54,3	60,3
W 67	20	50	67	76
W 80	20	50	80,5	88,9
W 105	20	50	106	114

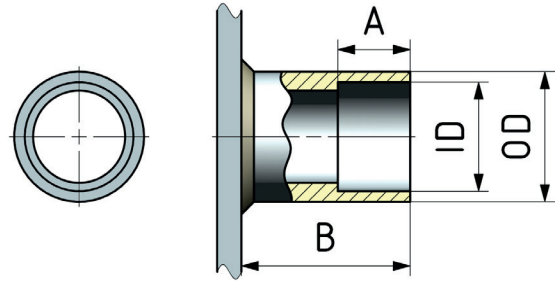

Rotalock Connection (RL)

Dimensions		
CODE	ID	T
RLA16	16,2	1"14-UNS
RLA19	19,4	1"14-UNS
RLB22	22,6	1 ¼"12-UNF
RLB28	28,8	1 ¼"12-UNF
RLC28	28,8	1 ¼"12-UN
RLC35	35,4	1 ¼"12-UN
RLC42	42,3	1 ¼"12-UN

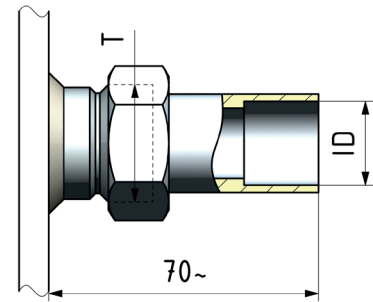

Rotalock Valve Connection (RLV)

Dimensions		
CODE	ID	T
RLVA16	16,2	1"14-UNS
RLVA19	19,4	1"14-UNS
RLVB22	22,6	1 ¼"12-UNF
RLVB28	28,8	1 ¼"12-UNF
RLVB28	28,8	1 ¼"12-UN
RLVC35	35,4	1 ¼"12-UN
RLVC42	42,3	1 ¼"12-UN

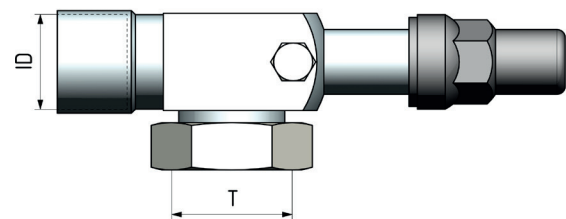

## Flexible Coupling (FLC)

Dimensions					
CODE	A	B	C	D	E
J3 FLC089	165	115	50	88,9	80
J4 FLC114	200	145	50	114,3	100
J5 FLC140	245	175	50	139,7	100
J6 FLC168	275	205	55	168,3	150
J8 FLC220	345	265	60	219,1	150

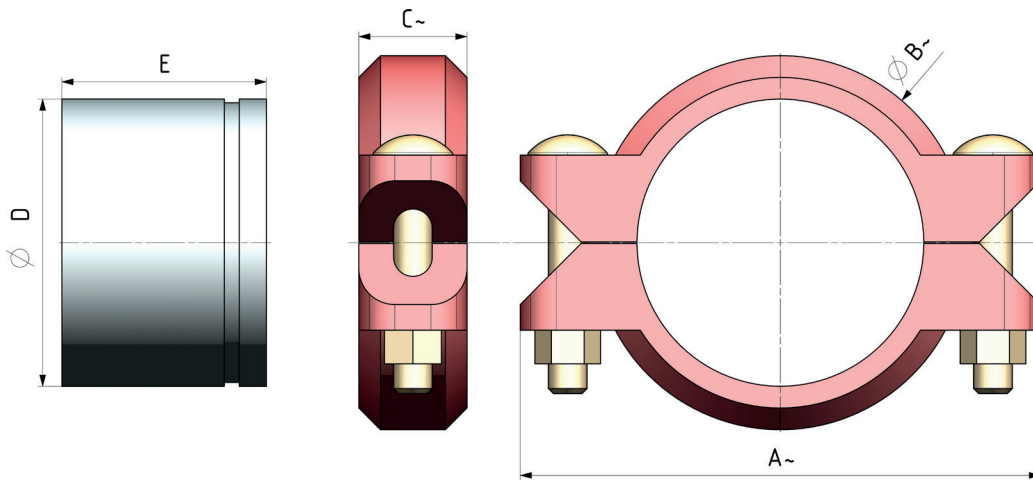

## Water Connection Types

Dimensions			
CODE	G	G(mm)	E(mm)
G1	G 1"	-	-
G11	G 1 1/2"	-	-
G2	G 2"	-	-
G21	G 2 1/2"	-	-
G3	G 3"	-	-
G4	G 4"	-	-
J4	-	114,3	100
J5	-	139,7	100
J6	-	168,3	100

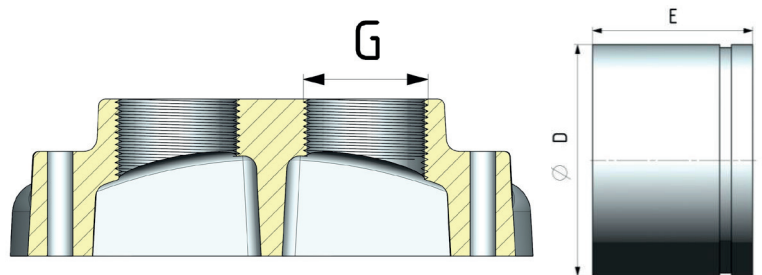

## SPARE PARTS

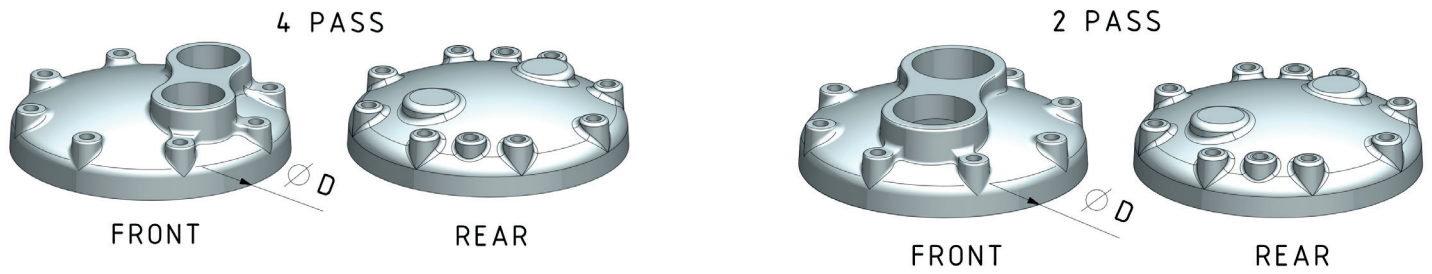

## Condenser Caps

Dimensions				
CODE	D	PASS	WATER CONNECTION	SUITABLE WITH
K1704	170	4	G 1"	RKDEW20-RKDEW35
K2004	200	4	G 1 1/2"	RKDEW(45,55,65,60C,75C,90C)
K2002	200	2	G 2"	RKDEW60-RKDEW180
K2502	250	2	G 2 1/2"	RKDEW200-RKDEW285
K2952	295	2	G 3"	RKDEW315-RKDEW450
K3502	350	2	G 4"	RKDEW480-RKDEW675
K4302	430	2	DN125 (Victualic)	RKDEW760-RKDEW840
K4802	480	2	DN150 (Victualic)	RKDEW940-RKDEW1100
K5302	530	2	DN150 (Victualic)	RKDEW1220-RKDEW1360
K5802	580	2	DN150 (Victualic)	RKDEW1520-RKDEW1680

## Condenser Gaskets

Dimensions			
CODE	D	PASS	SUITABLE WITH
KC1704	170	4	RKDEW20-RKDEW35
KC2004	200	4	RKDEW(45,55,65,60C,75C,90C)
KC2002	200	2	RKDEW60-RKDEW180
KC2502	250	2	RKDEW200-RKDEW285
KC2952	295	2	RKDEW315-RKDEW450
KC3502	350	2	RKDEW480-RKDEW675
KC4302	430	2	RKDEW760-RKDEW840
KC4802	480	2	RKDEW940-RKDEW1100
KC5302	530	2	RKDEW1220-RKDEW1360
KC5802	580	2	RKDEW1520-RKDEW1680

OTHERS

Zinc Anode

It is used the same type of zinc anode rod in all products.

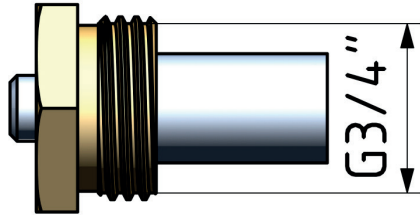

Compressor Mounting Platform	
Shell Diameter	Code
140 mm	KPAY 140
168 mm	KPAY 168
194 mm	KPAY 194

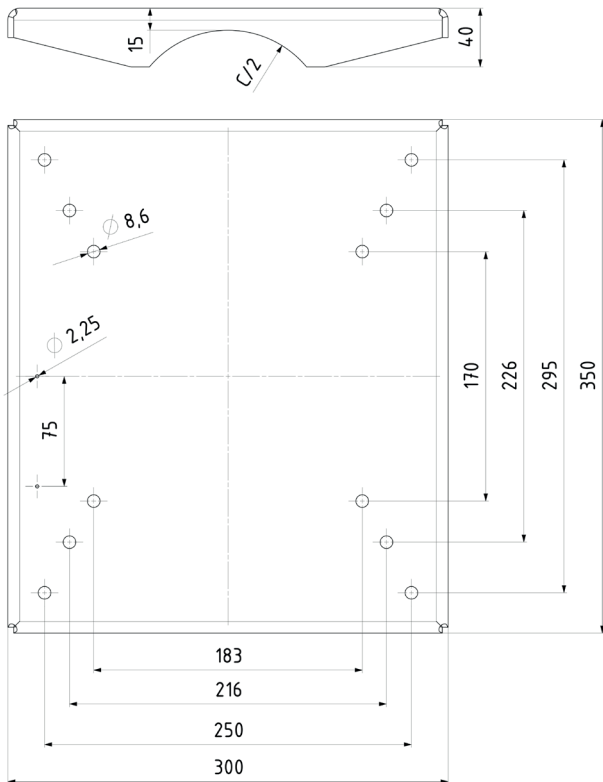

D: Ø 140 - 168

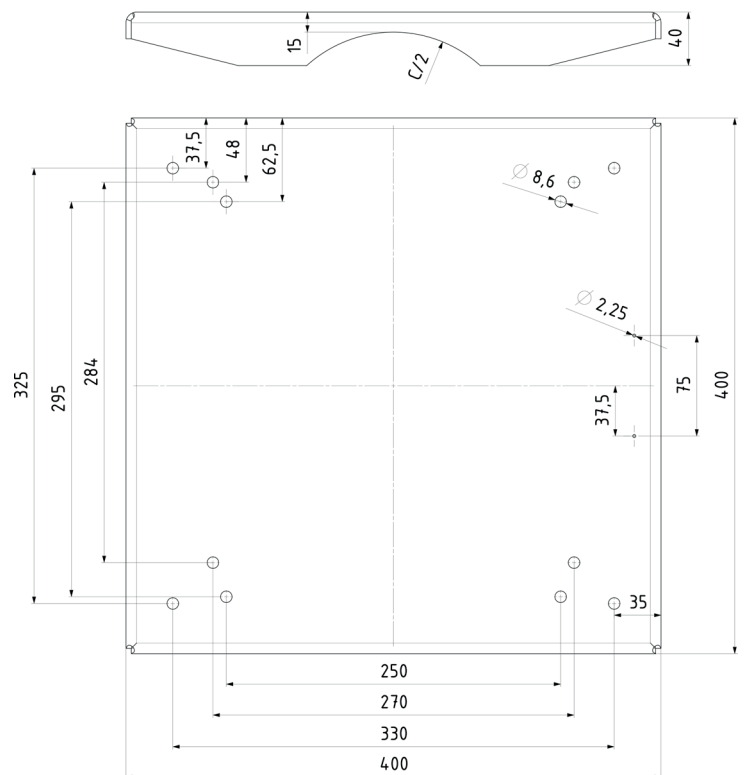

D: Ø 194





© 2024 Refkar All Rights Reserved.



Refkar Soğutma ve Isı Transfer Cihazları San. Ve Tic. Ltd. Şti

Office Address: Yeşilköy Mah. Atatürk Cad. EGS Business Park Blokları  
B3 Blok No:167 Kat:3 Bakırköy/İstanbul – Türkiye / Tel: +90 212 671 95 99

Factory Address: Kırklareli Organize Sanayi Bölgesi 15 Sk. No: 6  
Kızılıkdere Köyü Mevkii Merkez/Kırklareli – Türkiye / Tel: +90 288 502 34 08